



**Save more.
See more.
Sell more.**

**Aerofoil + Nualight integrated airflow
technology lighting system**



One complete solution to save energy and enhance food display.

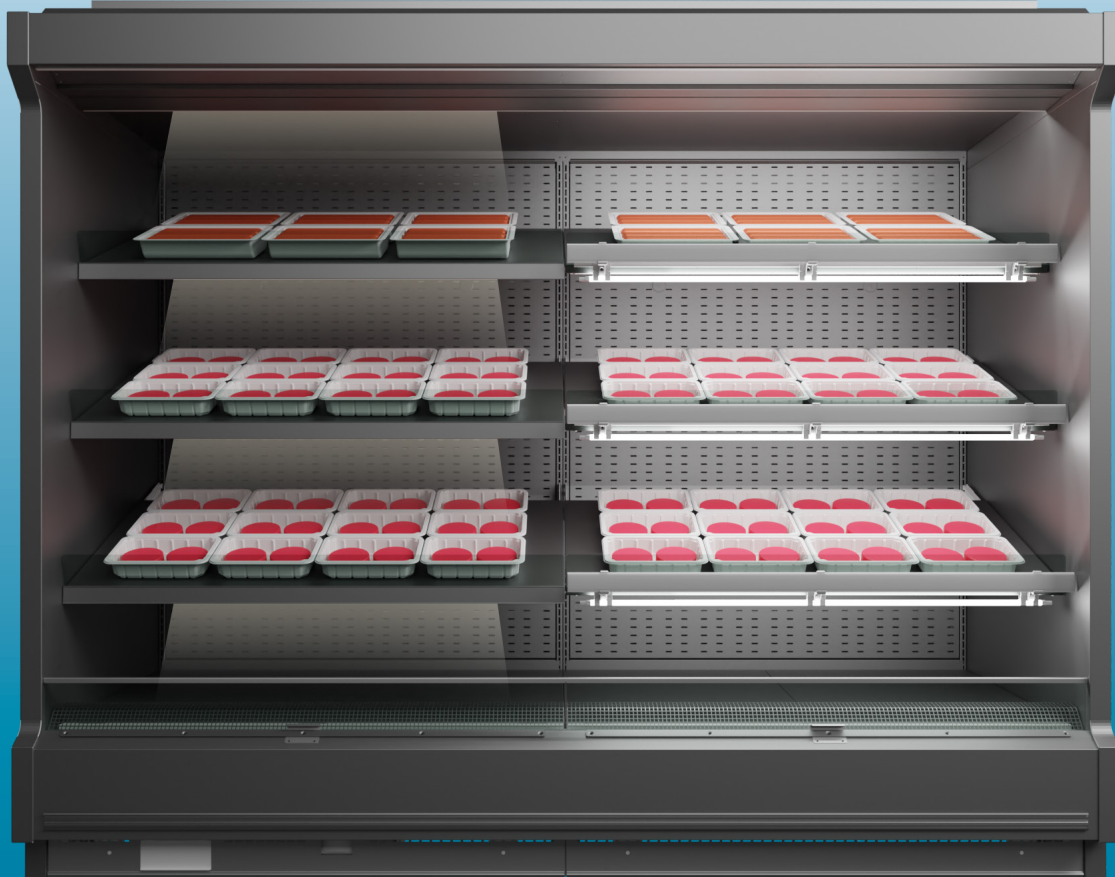

Standard shelf lighting

With Aerofoils + Nualights



The world's leading air-guide technology, Aerofoil, has partnered with Nualight premium shelf lighting to create the ultimate combined solution - Aerofoil Air-Guides + Integrated Low-Energy shelf lighting.

How do Aerofoils Work?

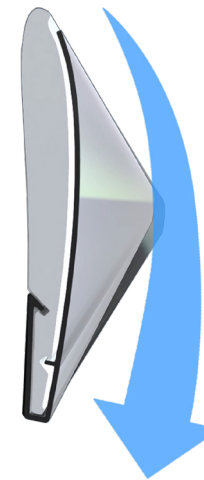
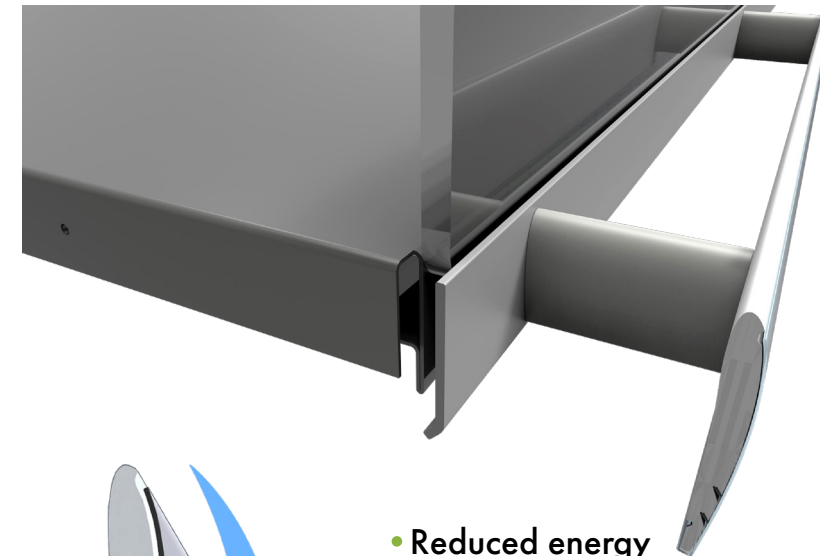

Airflow is directed back into the display fridge

- Reduced energy consumption by up to 40% according to lab tests (25% in store)
- Consequent savings as well as a major reduction in carbon footprint
- Reduced product shrinkage due to stabilising effect on product temperatures

Two leading technologies seamlessly integrated on the shelf edge.

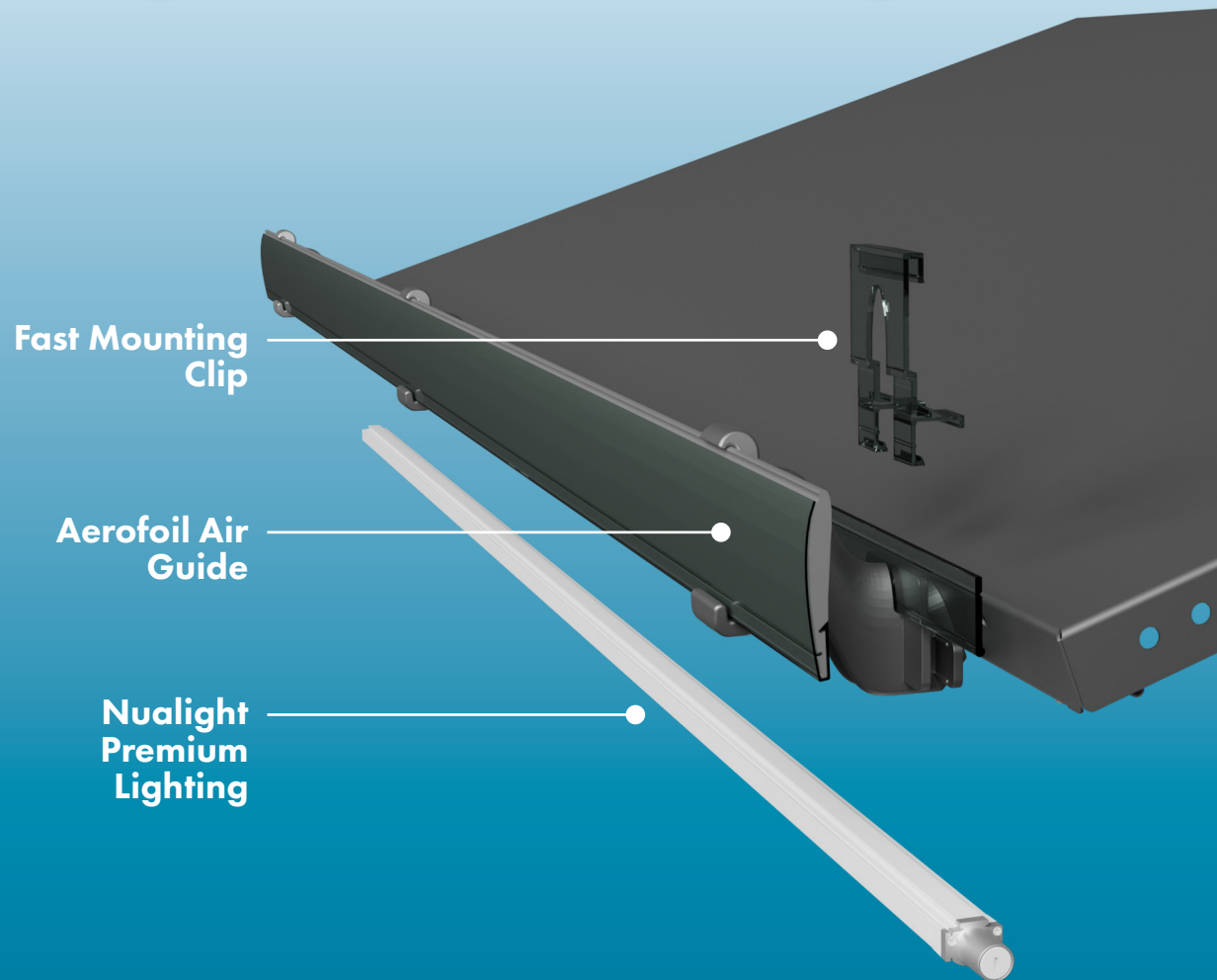

The ultra flexible, integrated lighting solution can be retrofitted at any time, either during the installation of Aerofoils or on shelves with Aerofoils already present.



Aerofoils improve airflow to reduce product temperatures, minimising food waste and saving energy costs. Nualight's high-performance LED's outperform conventional lighting on efficiency, whilst enhancing food display to help drive sales.

Why choose Aerofoil + Nualight?

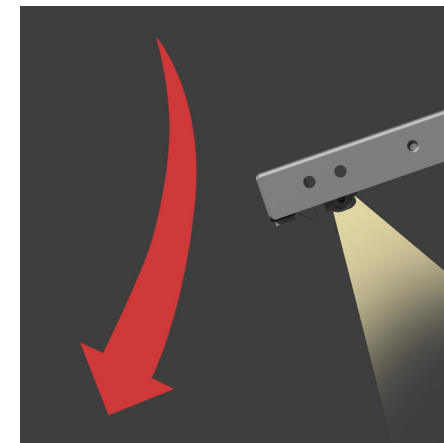

Standard lighting position

Traditional under shelf lights sit far back = shadows / poor product lighting. Air is spilled out of the display cabinet and into shopping aisles.

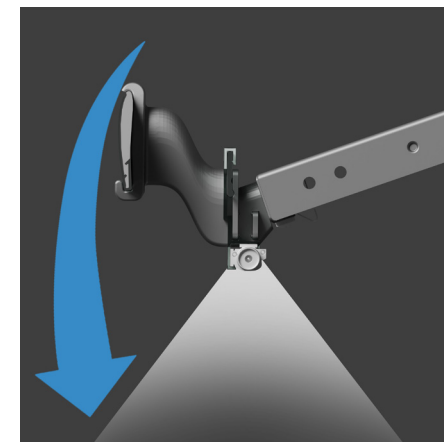

With Aerofoil + Nualight

Aerofoil + Nualight system = enhanced lighting + energy savings. Airflow is directed back into the display cabinet.

Retrofit during or after Aerofoil installation

Aerofoils save energy by guiding air in display chillers.
Nualight low-energy lighting cuts lighting energy and provides superior product display.



Before



After

The Nualight ION horizontal 5.5W LED is an ultra low energy refrigeration lighting product that significantly outperforms regular under-shelf lighting solutions. Shown here with integrated Aerofoil air guiding technology.



Easy installation

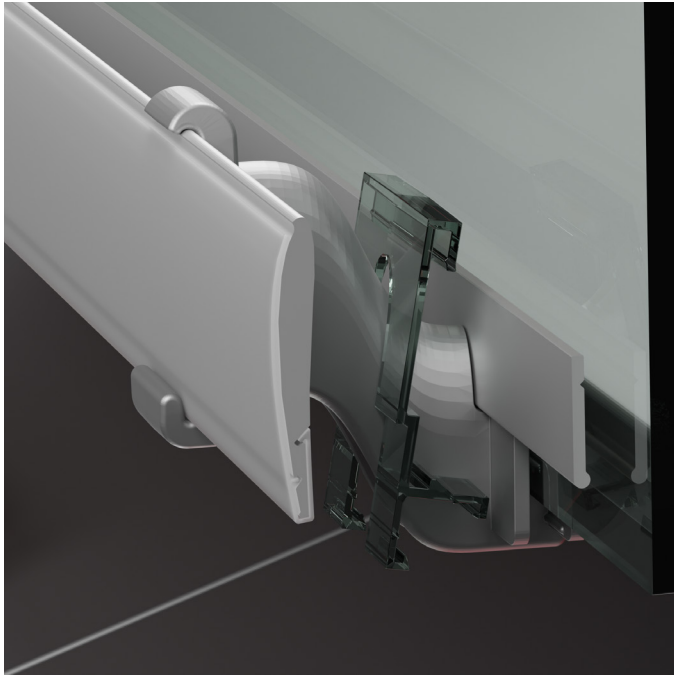

The quick-clips snap on to the brackets that hold the Aerofoil blade in place. The Nualight then simply 'clicks' into the bracket and sits in the ideal position.

